

Low-Level Order Picker with Minimast & Raising Platform

OEH 120 / OEP120 / OLH200-250 / OLP200-250

Picking efficiency defined with several key features and benefits like high-lifting operator-oriented 3D entry, dampened, wide walk-through platform, XControl 200° steering, boost effect and ergo-lift forks make these trucks the quickest and most ergonomic low-level order pickers.



	0	Specifications		OEH 120	OEP 120	
Distinguishing mark	1.2	Manufacturer's type designation				
	1.3	Drive: electric (battery or mains), diesel, petrol, fuel gas		Electric	Electric	
	1.4	Operator type: hand, pedestrian, standing, seated, order-picker, tow tractor		Order picker	Order picker	
	1.5	Load capacity/rated load	Q	t	1200	1200
	1.6	Load center distance	c	mm	600	600
	1.7	Rated drawbar pull	F	N		
	1.8	Load distance, center of load axle to fork	X		785	785
	1.9	Wheelbase	y	mm	1929	1929
	Weight	2.1	Service weight incl battery		kg	2556
2.2		Axle load, with load, front/rear		kg	1059 / 1497	972 / 1448
2.3		Axle load, without load, front / rear		kg	940 / 416	853 / 367
2.4		Axle load, fork outreached with load, front / rear		kg		
2.5		Axle load, fork retracted with load, front / rear		kg		
Tires, Chassis	3.1	Tires			Vulkollan	Vulkollan
	3.2	Tyre size, drive side		mm	250	250
	3.3	Tyre size, load side		mm	85	85
	3.4	Dimensions additional wheels (castor wheels)		mm	180 x 65	180x65
	3.5	Wheels, number front/rear (drive side/load side, x = driven wheels)			4 / 1x1	4 / 1 x 1
	3.6	Track, drive side	b10	mm	494	494
	3.7	Track, load side	b11	mm	355	355
Dimensions	4.1	Tilt of mast/fork carriage, forward/backward		Grad		80
	4.2	Height, mast lowered		mm	1394 / 2244	1173
	4.3	Free lift		mm		
	4.4	Lift height H = h13+h3		mm	765 / 1115	765 / 1115
	4.5	Height, mast extended		mm	1275 / 1625	1275 / 1625
	4.6	Straddle lift		mm		
	4.7	Height of overhead guard (cabin)		mm		
	4.8	Seat height/stand height		mm	150	123
	4.10	Height of wheel arms		mm	80	
	4.11	Additional lift		mm		
	4.12	Coupling height		mm		
	4.14	Stand height, elevated		mm	1000	
	4.15	Height lowered		mm	85	85
	4.19	Overall length		mm	2471	2471
	4.20	Length to face of forks		mm	1321	1321
	4.21	Overall width		mm	800	800
	4.21.1	Width over stabilizers		mm	56 / 186 / 950-1450	561 / 185 / 950-1450
	4.22	Fork dimensions		mm		
	4.23	Fork carriage to ISO 2328, class / form A, B		mm		
	4.24	Width of fork carriage		mm	540 / 570	540 / 570
	4.25	Width over forks, min/max		mm		
	4.26	Distance between wheel arms		mm		
	4.27	Width across guide rolls		mm		
	4.28	Reach distance		mm		
	4.29	Reach lateral		mm		
	4.30	Reach lateral from vehicle centerline		mm		
	4.31	Ground clearance, mast		mm		
	4.32	Ground clearance, center of wheelbase		mm	25	25
	4.33	Aisle width with pallet 1000 x 1200, crosswise		mm		
	4.34	Aisle width for pallet 800 x 1200, lengthwise		mm	2881	2881
	4.35	Turning radius		mm	2106	2106
4.37	Length incl reach legs		mm			
4.38	Distance to swivelling-fork pivot		mm			
Performance data	5.1	Travel speed, with/without load		km/h	9.0 / 9.0 (opt 9 / 13)	9.0 / 9.0 (opt 9 / 13)
	5.1.1	Travel speed with/without load, backwards		km/h		
	5.2	Lift speed, with/without load		m/s	0.20 / 0.41	0.20 / 0.41
	5.3	Lowering speed, with/without load		m/s	0.30 / 0.36	
	5.4	Reach speed, with / without load		m/s		
	5.7	Gradient, with/without load		%	7 / 15	7 / 15
	5.8	Max gradeability, with / without load, 5 min rating		%		
	5.9	Acceleration time 0-10 m, with/without l		s		
	5.10	Service brake: electric, h			Electric	Electric
	5.10.1	Parking brake: electric, hydraulic			Electric	Electric
Electric engine	6.1	Drive motor, rating S2 60 min		kW	2.6	2.6
	6.2	Lift motor		kW	2.2	2.2
	6.3	Battery according to DIN 43531/35/36		A,B,C		
	6.4	Battery voltage / Battery capacity		V/Ah	24 / 465-620	24 / 465-620
	6.5	Battery weight		kg	366-493	366-493
	6.6	Power consumption according to VDI cycle		kWh/h		
Additional data	8.1	Speed regulation			Stepless	Stepless
	10.1	Operating pressure attachments		bar		
	10.2	Oil flow for attachments		l/min		
	10.7	Noise level at operator's ear, according to EN 12 0		db(A)	62	62
	11.1	Notes				

* varies according to battery size

All rights reserved to change above specifications

	0	OLH 200	OLH 250	OLP 200	OLP 250
Distinguishing mark	1.2				
	1.3	Electric	Electric	Electric	Electric
	1.4	Order picker	Order picker	Order picker	Hand
	1.5	2000	2500	2000	2500
	1.6	600	600	600	600
	1.7				
	1.8	960	960	960	960
	1.9	2054	2054	2054	2054
Weight	2.1	1215	1215	1079	1079
	2.2	1130 / 2085	1223 / 2492	1082 / 1997	1178 / 2401
	2.3	913 / 302	913 / 302	829 / 250	829 / 250
	2.4				
	2.5				
	2.6				
Tires, Chassis	3.1	Vulkollan	Vulkollan	Vulkollan	Vulkollan
	3.2	250	250	250	250
	3.3	85	85	85	85
	3.4	180x65	180x65	180x65	180x65
	3.5	4 / 1 x 1	4 / 1x 1	4 / 1x 1	4 / 1x 1
	3.6	494	494	494	494
	3.7	365	365	365	365
Dimensions	4.1				
	4.2	1394 / 2244	1394 / 2244	1173	1173
	4.3				
	4.4	220	220	220	220
	4.5				
	4.6				
	4.7	150	150	123	123
	4.8				
	4.10				
	4.11				
	4.12				
	4.14	1000	1000		
	4.15	85	85	85	85
	4.19	2421	2421	2421	2421
	4.20	1271	1271	1271	1271
	4.21	800	800	800	800
	421.1	60 / 175 / 900-3600	60 / 175 / 900-3600	60 / 75 / 900-3600	60 / 175 / 900-3600
	4.22				
	4.23				
	4.24	480 / 660	480 / 660	480 / 660	480 / 660
	4.25				
	4.26				
	4.27				
	4.28				
4.29					
4.30					
4.31					
4.32	25	25	25	25	
4.33	3033	3033	3033	3033	
4.34	2898	2898	2898	2898	
4.35	2231	2231	231	2231	
4.37					
4.38					
Performance data	5.1	9.0 / 9.0 (opt 9 / 13)	9.0 / 13.0	9.0 / 9.0 (opt9.0 / 13.0)	9.0 / 13.0
	5.1.1				
	5.2	0.04 / 0.05	0.03 / 0.05	0.04 / 0.05	0.03 / 0.05
	5.3	0.05 / 0.03	0.05 / 0.03	0.05 / 0.03	0.05 / 0.03
	5.4				
	5.7	7 / 15	7 / 15	7 / 15	7 / 15
	5.8				
	5.9				
	5.10	Electric	Electric	Electric	Electric
	5.10.1	Electric	Electric	Electric	Electric
Electric engine	6.1	2.6	2.6	2.6	2.6
	6.2	2.2	2.2	1.2	1.2
	6.3				
	6.4	24 / 65-620	24 / 465-620	24 / 465-620	24 / 465-620
	6.5	366-493	366-493	366-493	366-493
	6.6	0.37	0.4	0.37	0.4
	6.7				
Additional data	8.1	Stepless	Stepless	Stepless	Stepless
	10.1				
	10.2				
	10.7	62	62	62	62
	11.1				

* varies according to battery size

All rights reserved to change above specifications

OEH 120

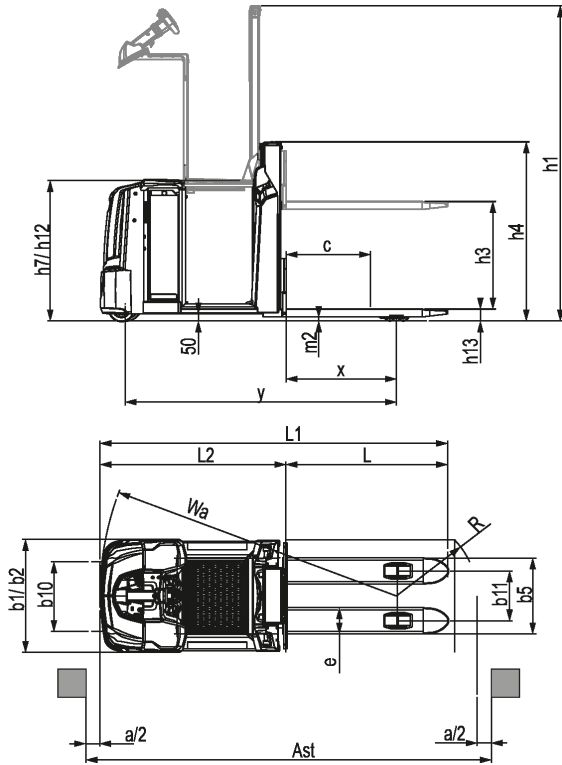

OEP120

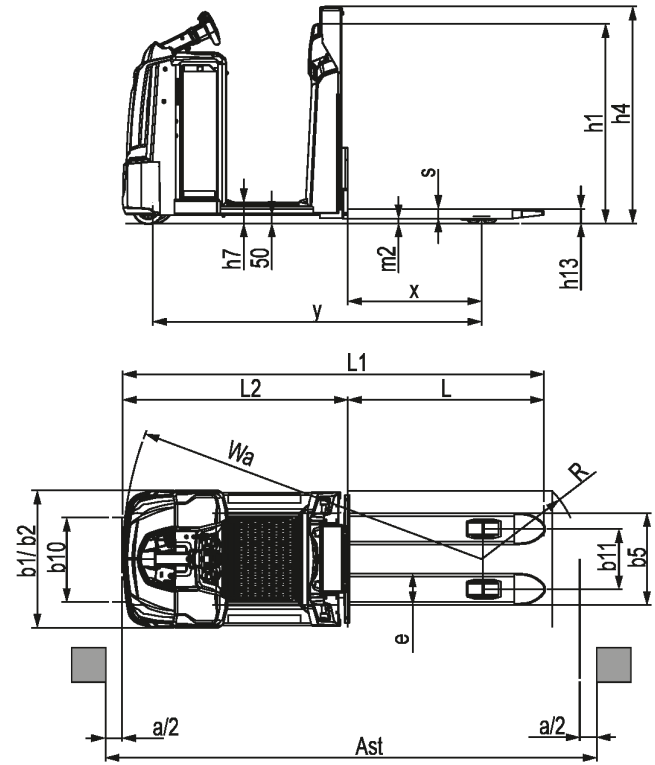

OLH 200 / 250

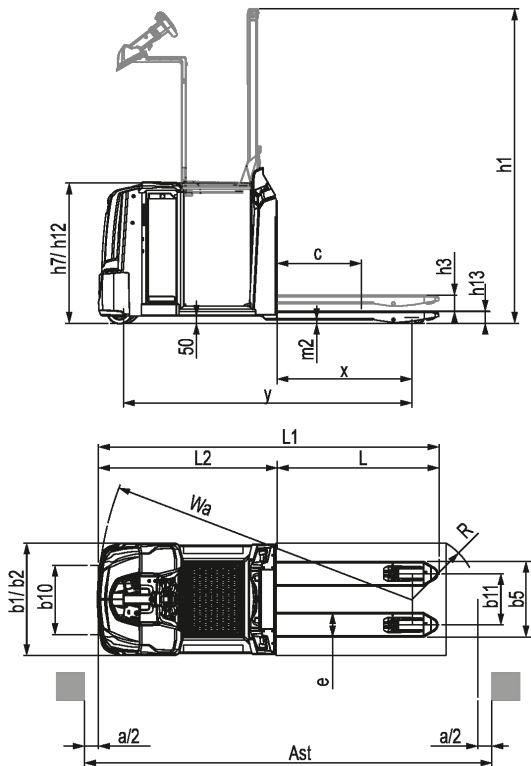

OLP 120 / 250

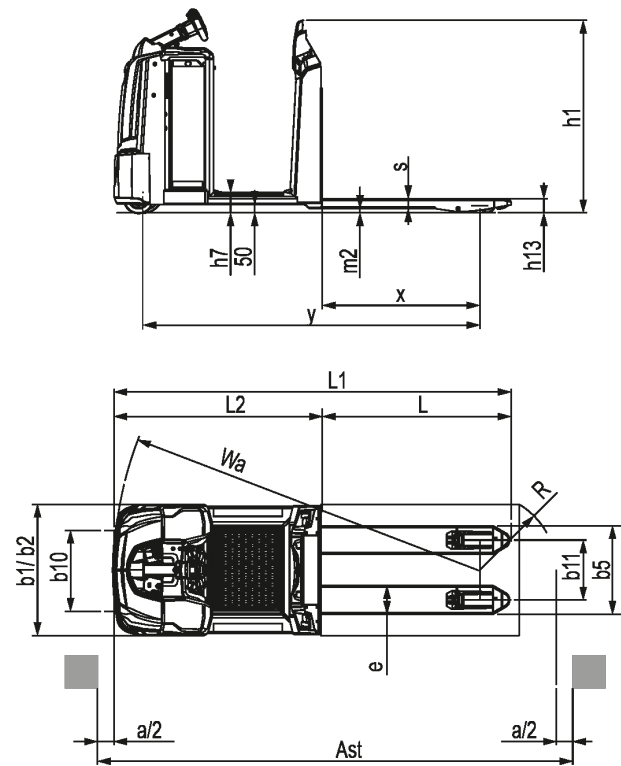

© 2022 Mitsubishi Logisnext Americas Inc. UniCarriers® is a registered trademark of Mitsubishi Logisnext Co., Ltd. Mitsubishi Logisnext Americas Inc. reserves the right to make product changes relating to colors, equipment, specifications or available options without notice. For more information, contact your UniCarriers Forklift representative.